

支点开闭型气动手指 Air Chuck

TMHC(Ø12~Ø32) Series

How To Order (型号表示方法)



TMHC 10 - RS2 - M

Bore 缸径	Auto Switch 磁性开关	Mounting Bracket 安装支架
10,16,20,25,32	Nil(空) None (无磁性开关) RS1 Switch 1EA(磁性开关1只) RS2 Switch 2EA(磁性开关2只)	Nil(空) None (无支架) M M Type Bracket (M型支架) B B Type Bracket (B型支架)

Specification (规格)

Bore(缸径)	Ø10	Ø16	Ø20	Ø25	Ø32	
Fluid(流体)	Air(空气)					
Action(动作形式)	Double Acting(双动)					
Pressure Range(使用压力范围)	0.15~0.7Mpa					
Amb.Temp(环境及流体温度)	0~+60°C(未冻结)					
Max. Operation Frequency(最高动作频率)	120次/分钟					
Lubrication(润滑)	Not Required(不需要)					
	Cylinder(气缸)					
Lever Section(爪片)	Required (Apply Lubricating Oil)(抹润滑油)					
Length Of Max. Gripping Point(最大爪臂长度)(L)	30	40	60	70	85	
Lever Open/ Close Angles(夹爪开关角度)	-10~30°					
Theoretical Holding Force (理论夹持力矩)(M)(Kgf-cm)	Closed Side(闭侧)	0.16XP	0.8XP	1.7XP	3.4XP	6.1XP
	Opened Side(开侧)	0.26XP	1.1XP	2.3XP	4.3XP	8.1XP
Effective Gripping Force (有效夹持力)(F)(Kgf)	F=M/L × 0.85					
Pipe Size(接管口径)	M3×0.5	M5×0.8				
Magnet(磁环)	Built-in Magnet(Standard)(标准内置磁环)					

Internal Structure (内部结构)

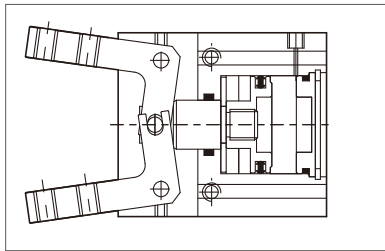

Gripping Force Characteristic(夹持力特性图)

TMHC External gripping force(闭合夹持力)

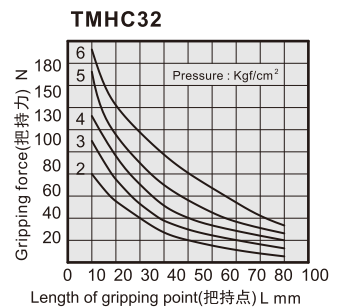
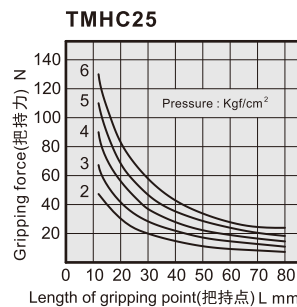
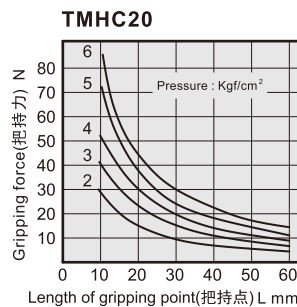
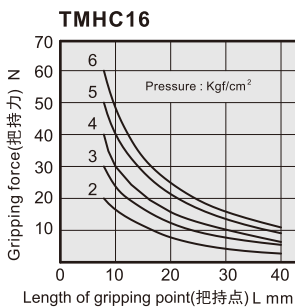
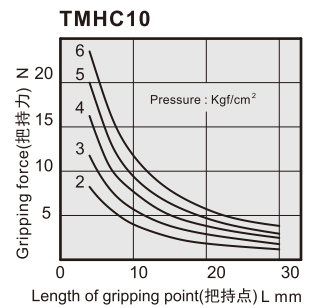
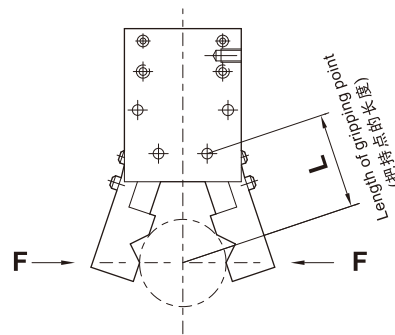

Effective Gripping Force(有效夹持力)

Bore size (缸径)(mm)	The smallest operating pressure (最小操作压力)(Mpa)	Thread Port (手指螺纹孔)(mm)	Effective Gripping Force (有效夹持力)Kgf(N)	
			Open(开)	Close(闭)
Ø10	0.22	4 - M3x0.5P	Open(开)	0.3 (3.6)
			Close(闭)	0.2 (2.2)
Ø16	0.1	4 - M3x0.5P	Open(开)	1.5 (15.2)
			Close(闭)	1.1 (11.1)
Ø20	0.1	4 - M4x0.7P	Open(开)	3.2 (31.9)
			Close(闭)	2.4 (23.6)
Ø25	0.1	4 - M5x0.8P	Open(开)	6.0 (59.6)
			Close(闭)	4.8 (47.2)
Ø32	0.1	4 - M6x1.0P	Open(开)	11.4 (112.4)
			Close(闭)	8.6 (84.6)

Note : The gripping force is the force of open and close gripper which is in the length of gripping point is 30mm and acting pressure is 0.5Mpa.

注：夹持力是爪臂接点长度为30mm，动作压力为0.5Mpa时，开关爪片时产生的力。

Mounting Type (安装方式)

1. Use the thread in the bottom(使用底部的螺纹孔)
2. Use the thread in the side of body(使用本体侧面的螺纹孔)

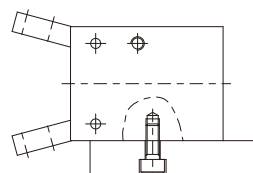
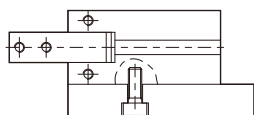

3. Use M type Mounting bracket in the bottom.
(在底部使用M型底座固定)

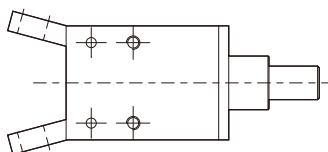

4. Use B type Mounting bracket in the bottom.
(在底部使用B型底座固定)

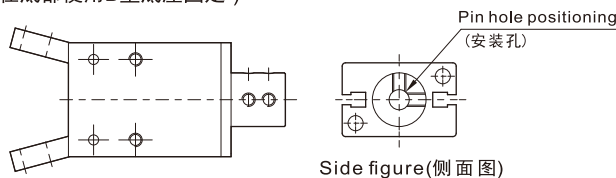

Mounting Bracket (安装支架)

- M type Mounting bracke (Suitable for internal mounting) (M型安装支架(适用于内圆固定使用))

Model (型号)	A	B	C	D	E	F	G	H	I	J	K
M10	10	10	2	8	12	11	23	17	10	16	3.5
M16	15	15	3	10	16	17	34	26	14	22	4.5
M20	15	15	3	10	18	21	45	35	16	26	5.5
M25	25	17	5	14	26	26	52	40	20	32	6.6
M32	25	20	6	16	30	34	60	46	26	40	6.6

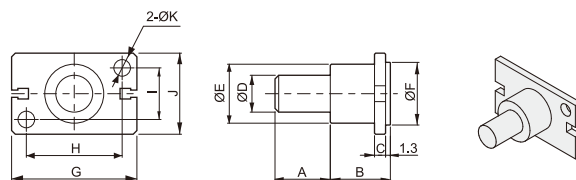

- B type Mounting bracke (Suitable for external mounting) (B型安装支架(适用于外圆固定使用))

Model (型号)	A	B	C	D	E	F	G	H	I	J	K	L
B 10	4	15	10	5	-	M3 x 0.5p	11	23	17	10	16	3.5
B16	6	20.5	16	5	6	M4 x 0.7p	17	34	26	14	22	4.5
B20	8	20.5	20	7	7	M4 x 0.7p	21	45	35	16	26	5.5
B25	10	30.5	25	8	10	M4 x 0.7p	26	52	40	20	32	6.5
B 32	12	40.5	32	10	15	M4 x 0.7p	34	60	46	26	40	6.5

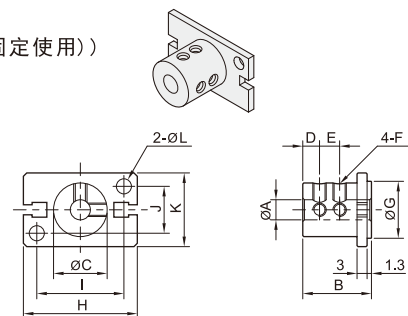

支点开闭型气动手指 Air Chuck

TMHC(Ø12~Ø32) Series

Dimensions(mm)(外形尺寸图(毫米))

TMHC10

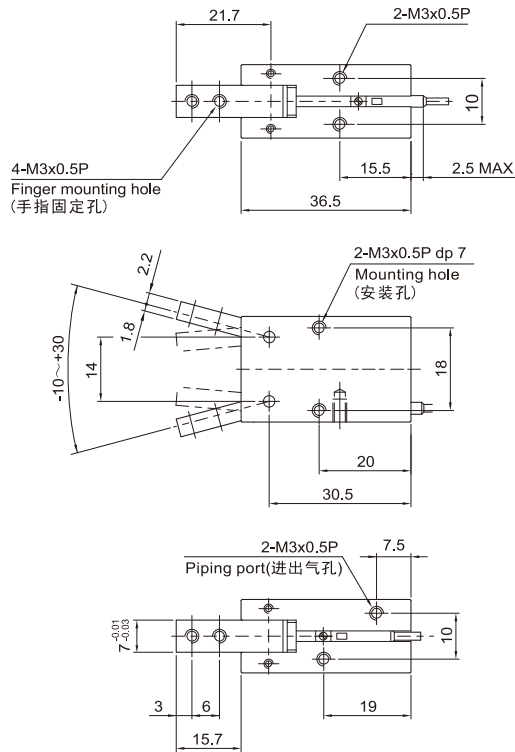

TMHC10-RS2

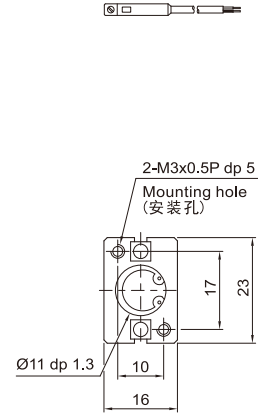

Dimensions(mm)(外形尺寸图(毫米))

TMHC16

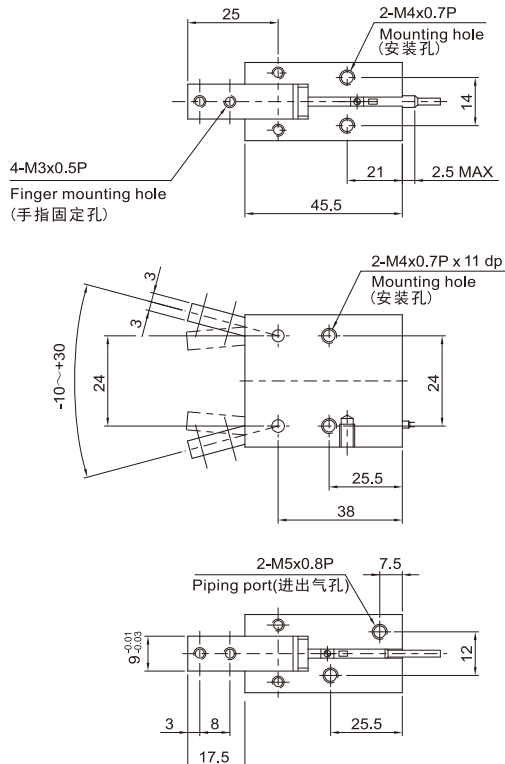

TMHC16-RS2

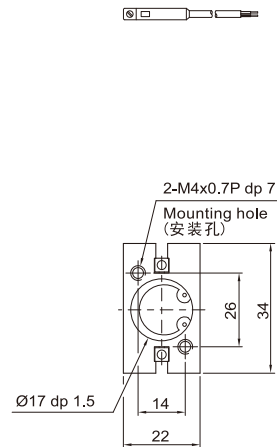

Dimensions(mm)(外形尺寸图(毫米))

TMHC20

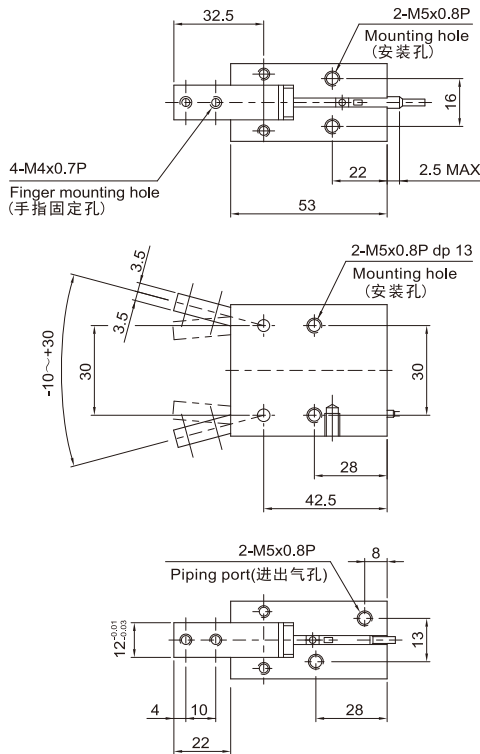

TMHC20-RS2

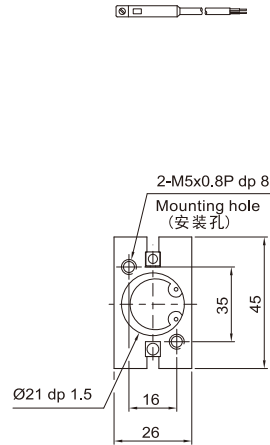

Dimensions(mm)(外形尺寸图(毫米))

TMHC25

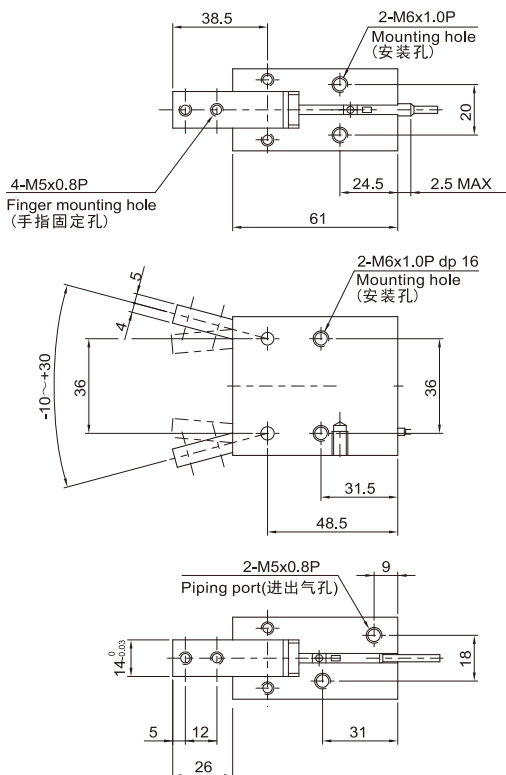

TMHC25-RS2

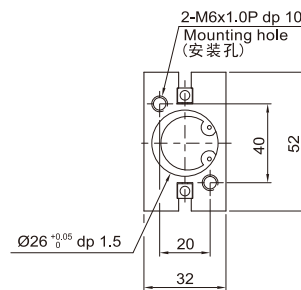

支点开闭型气动手指 Air Chuck

TMHC(Ø12~Ø32) Series

Dimensions(mm)(外形尺寸图(毫米))

TMHC32

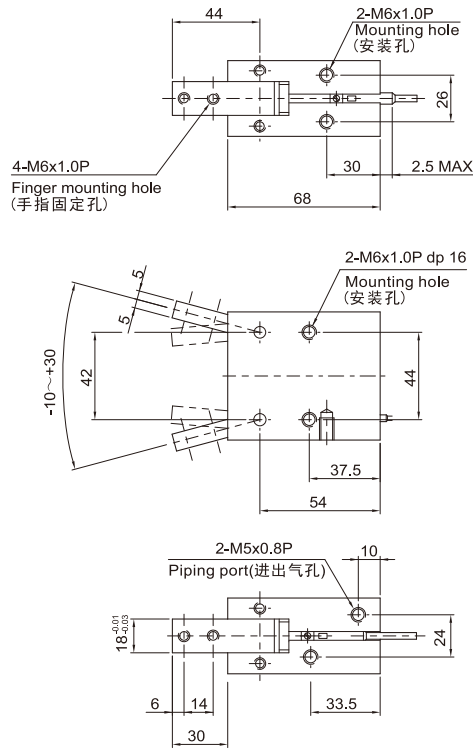

TMHC32-RS2

